

Comprehensive Rectifier Service Support Rectifier One-Stop-Shopping

*A complete Portfolio of Dedicated Service Solutions with
Bottom Line Results*



ABB Power Electronic Systems
Experts in High Power Converters



*ABB knows how important a safe and reliable rectifier installation is to your success. Already during system design, we pay attention to high **reliability**, easy maintenance, adequate sizing and **safety** of operation. For installed rectifier systems, our ultimate concern is to secure your investment for maximized production. With ABB's **One-Stop-Shopping** rectifier service you realize maximum plant performance and efficiency.*

Competence makes the difference

ABB has **over 100 years of experience** in rectification and conversion of utility power to process power for the production and refinement of primary metals and chemicals. With this heritage, ABB's rectifier system services provide the knowledge and experience required to keep your assets operating at peak reliability and efficiency.

*ABB provides a full **scope of services** from start-up and commissioning **through lifecycle** support for the entire rectification and power distribution systems. Our broad service portfolio lays the foundation for end-to-end support and optimization of your operation.*

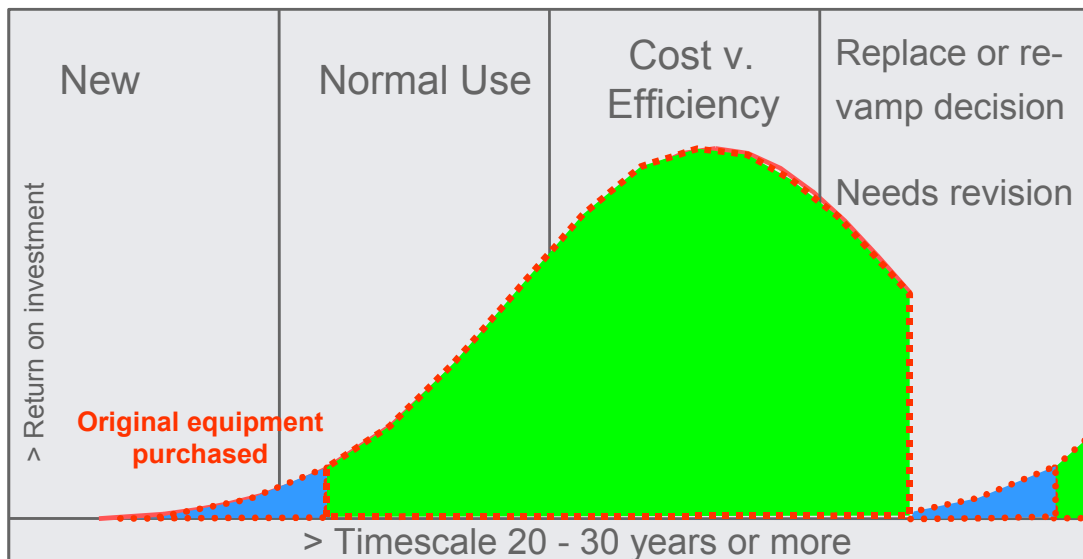

One-Stop-Shopping

ABB's experienced rectifier teams stand ready to assist you with any and all rectifier system needs offering a unique **One-Stop-Shopping** capability. Depth of knowledge and resources means that **all rectifier system aspects, from the AC utility, to DC bus powering your process, are handled from a single location.** Our unmatched experience, equipment quality and attention to your requirements, ensures that the most reliable and optimized AC to DC power conversion system is delivered, providing outstanding value.

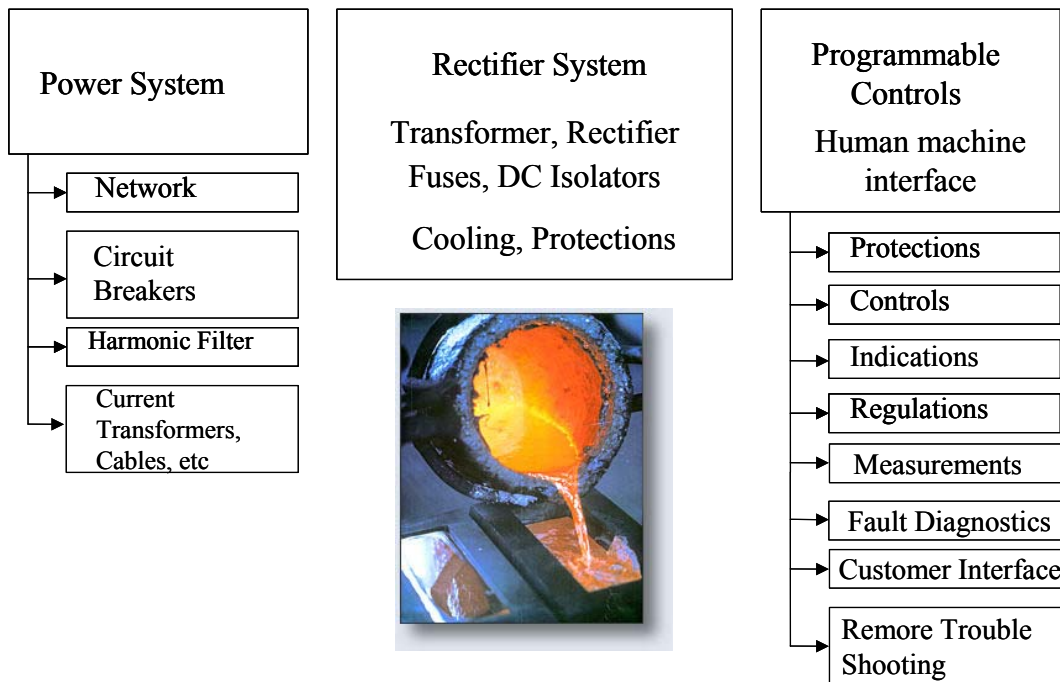

Across a full range of power requirements, ABB provides custom solutions based upon standardized designs. ABB maintains the flexibility to satisfy each application's unique requirements while **maximizing economies of scale, speed of implementation, serviceability and other benefits.**

Below are several examples of services that can be tailored to the specific needs of each plant.

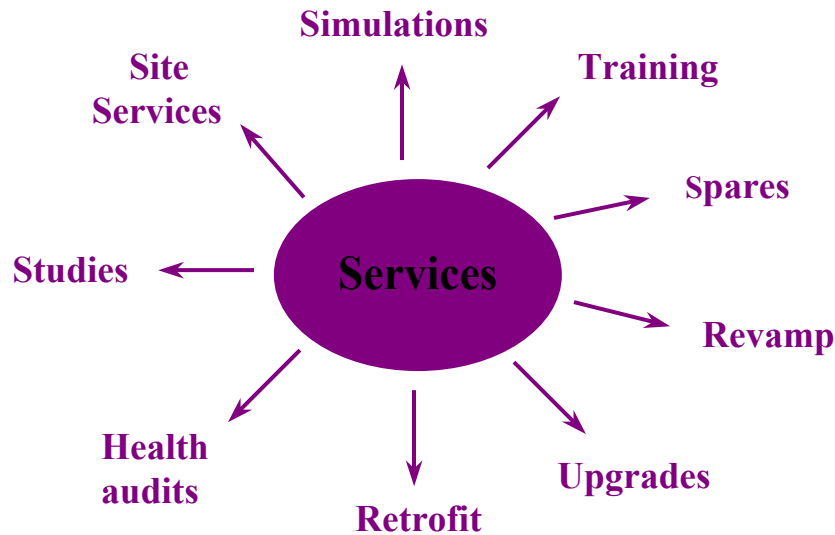

- Rectifier Transformer Service and Repair



Rectifier transformers are often subjected to very severe duty due to a number of factors, such as constant operation at full power. Further rectifiers add a significant harmonic load to the rectifier transformer. Commutation notches, Eddie current heating, Switching, Lightning strikes and other phenomena will have further impact on insulation life and other factors impacting the overall unit life expectancy.

*ABB offers a range of transformer **testing and services** from preventive maintenance to complete tap changer service, transformer overhaul and repair.*

- Rectifier System Health Audit

A typical system health audit will normally include a detailed performance review of all major components of the rectifier system. It often includes various temperature measurements of components and connections, thermal scans, transformer oil sample and test, review and checking of various alarm and trip points, functional tests of critical control relay, over voltage and over current protections, harmonics and power factor measurements and a general review of the system performance against start-up data where such data is available and a general performance review against customer needs and requirements. Such health audits and studies can also be performed to evaluate plant rating. This helps to create a road map for revamps / upgrades / retrofits.

*Further the scope of the health audit may be expanded to include review and identification of process bottlenecks and provide remedial **recommendations for the elimination of such bottlenecks to help reach targeted production levels and energy consumption objectives**. A detailed report with recommendations will be issued as part of the health audit.*

- Upgrade & Retrofit

An operator should continually inquire about the status of his plant:

- How **safe** are the oil-cooled rectifiers?
- How much are we **spending** on air-cooled rectifiers?
- How much are we spending on maintenance and how much could we **save** through increased reliability and availability?
- Are we still getting an **optimum return** on investment using the present control systems?
- How can we add new protection concepts?

*We are specialized in **improvement of existing equipment** with the objective of increasing its life-span and maximizing your investment. Upgrade and retrofit opportunities, identified during audits, feasibility studies, functional tests and failure analysis, can lead to increased performance and efficiency.*

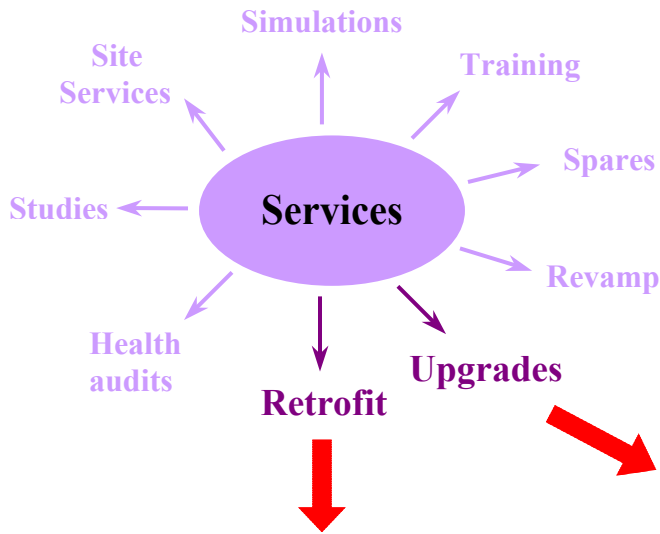

Retrofitting: Adding something to improve performance of equipment

The nature of any industrial process is that equipment begins to depreciate as soon as it is placed into operation. By retrofitting, the performance can be increased.

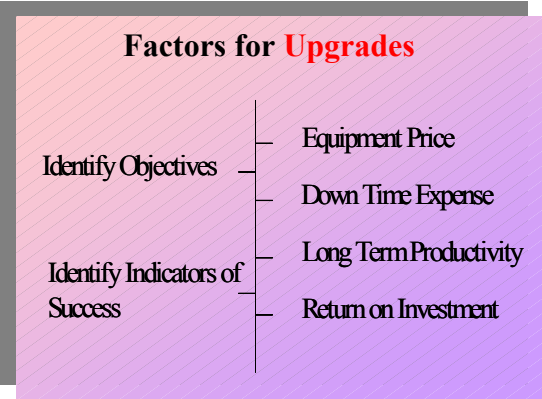

- Power Electronics / Rectifier Bridge Upgrades

Semiconductor power devices, such as diodes and thyristors as used on older rectifier designs, usually were matched to provide optimum current sharing and reliable operation. Occasionally such closely matched devices may no longer be available from the semiconductor manufacturers or from the original manufacturer of the rectifiers.

Further component aging may have caused deterioration in contact resistance, failed fuse

components or snubber circuits or otherwise degraded the power structure of the aging rectifier. Further spare parts may have become unavailable.



ABB offers a range of customized services on existing rectifier bridges that can help extend the life and increase the reliability of the existing system.

- Control Upgrades

Regardless of original rectifier manufacturer, it is becoming increasingly difficult and costly to refurbish **spare parts** for and to service aging rectifier control systems. Certain electronic components used on older analog and digital circuit boards are often no longer available and it is frequently difficult or even impossible for manufacturers to locate compatible replacement components. Controls for state-of-the-art rectifiers; offer a range of built-in advanced diagnostics tools and other features that assist a customer's maintenance staff in effective service and troubleshooting.

With **state-of-the-art technology** the customer can access their process easily via an optical connection. With the new control system, expansion or change to the control philosoph is easily performed.

*By replacing the old rectifier controls with ABB's modern AC 800PEC control platform, customers get **state-of-the art diagnostics** with full Industrial IT functionality and solve the problem of dwindling support and replacement parts for their old rectifier control at the same time.*

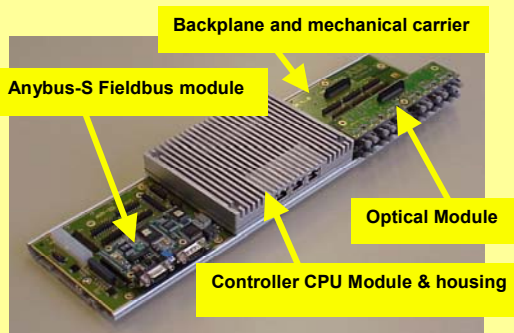

AC 800PEC; Unique Benefits (in ABB context)

- **Industrial IT**
 - Target level 2: integration
- **Speed**
 - Microsecond cycle time
- **Control development efficiency**
 - Matlab/Simulink for fast control loops instead of C/Assembler
 - What you simulate is what you execute
 - Interface to IEC61131 controller
 - AC 800M controller implemented
- **Web enabled**
 - Web server directly in controller, no additional PC necessary
- **Field bus connectivity**
 - Connects to any commonly used field bus via Anybus-S or CEX-Bus modules
- **I/O System**
 - ABB's standard S800 I/O's
- **Commissioning and Service Tool**
PECView

Typical Rectifier 12-Pulse Control System Utilizing ABB's AC 800PEC Controller

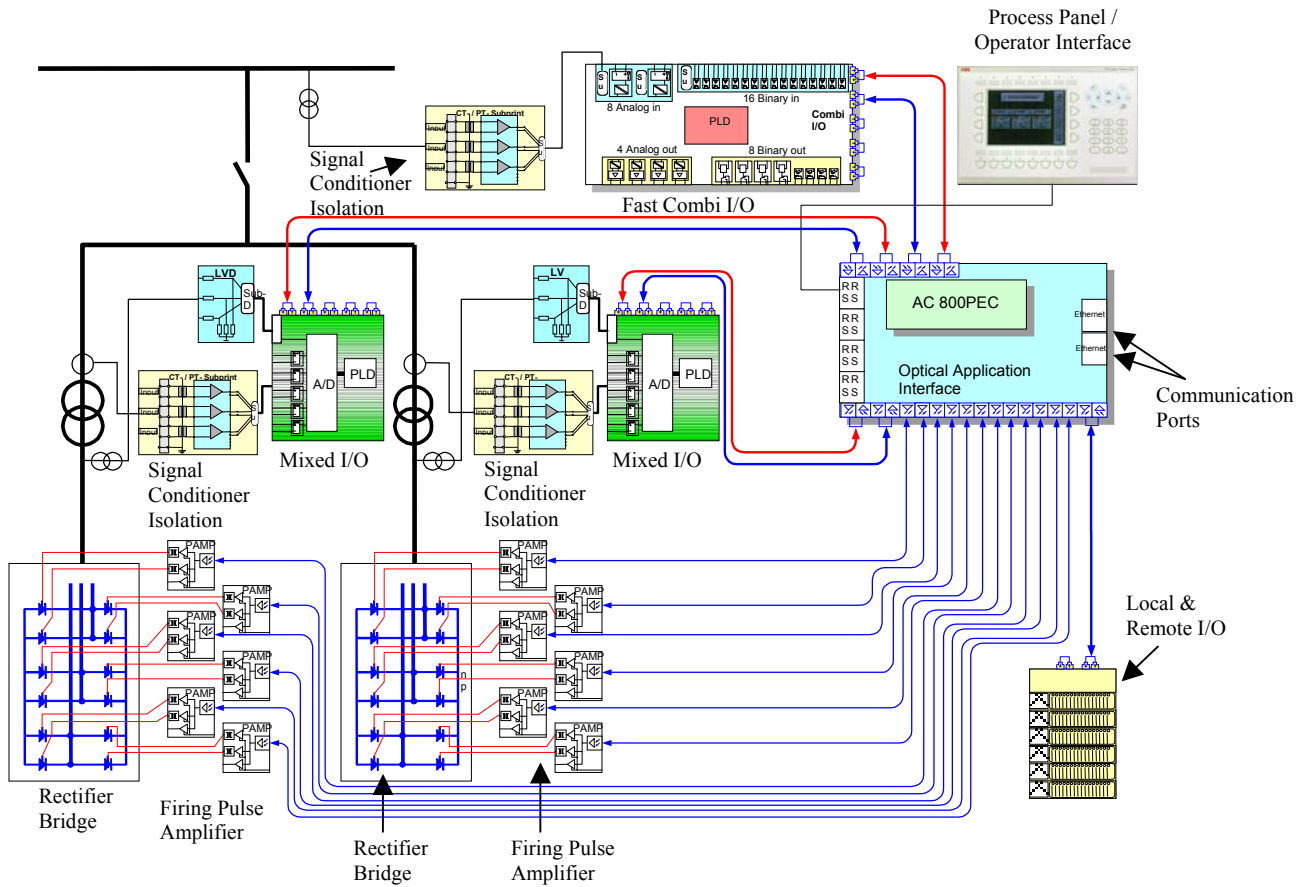

Overview with Links to External Systems

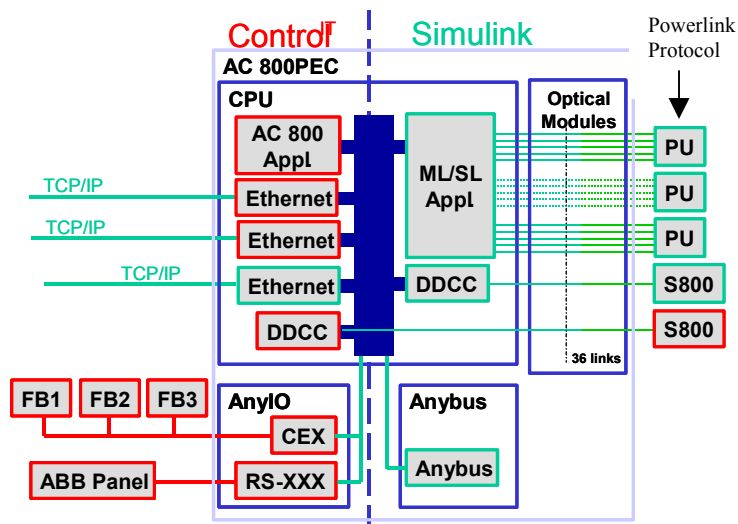

- Water Cooling System Rebuilds

Over the years all rectifier manufacturers and users switched over to water-cooled rectifier systems due to following inherent advantages related to water-cooled systems:

- **Higher reliability**

Simpler rectifier design, less material and components. Minimal vibrations of components and wires increase reliability of monitoring systems.

- **No pollution in the rectifier**

The persisting problem associated with air-cooled system of corrosion of contact surfaces of semiconductors and heat sinks is greatly reduced in case of water-cooled rectifiers.

- **Longer Lifetime**

- *Welded rectifier design*
- *Electrical contacts are nickel-plated*
- *Low temperature: Due to efficient cooling system, junction temperatures of semiconductors and fuses remain very low at normal operating currents. This also increases over load capability of semiconductors and fuses, particularly during faults. Hence component stress is significantly reduced.*

The time to modify the cooling system is before the first fire. Water cooling is gaining wide acceptance among insurance providers around the world, because it removes the danger of catastrophic loss from oil-cooled rectifiers fires.



Water-cooled thyristor-controlled rectifier for indoor installation. 45 KA, 770 V DC.

Before hot retrofit: 6x24 KA, 900 V DC oil-cooled rectifiers. After hot retrofit: 6x27.5 KA, 1500 V DC water-cooled rectifiers.



- **Less maintenance**

Closed loop water circuit with de-ionizing decreases daily maintenance:

- *Less influence of ambient pollution*
- *Less components*
- *Heat sinks don't need to be cleaned*
- *Rectifier is accessible during operation for inspection*

- **Reduced number of semiconductors**

Due to efficient cooling, the number of semiconductors and fuses required are lower than air-cooled systems. Fewer semiconductors results in better current distribution. This results in reduced peak loading on semiconductors and fuses.

- Harmonic and Power Factor Compliance

Depending on the terms of a customer's power purchase agreement, utilities typically charge their customers considerable fees for excessive VAR consumption and dictate requirements for maximum allowed harmonic distortion injected into the utility grid from any given plant.

Rectifiers, drives and other power electronic equipment typically generates system harmonics and contribute to lowering the system power factor. This effect impacts the cost of purchased power, system reliability and equipment life and has the potential of causing system upsets and equipment failures within the plant. ABB offers a range of **system studies and simulations** as well as equipment needed to remedy harmonics, system resonances and power factor issues. Using the latest in advanced simulation tools, we perform cursory system assessments to complete and comprehensive plant wide system studies. Following a complete analysis, we can provide **suitable system solutions**, such as harmonic filtering, switched capacitor banks, Static Var compensators and / or modification to existing systems as may be required.

- Breaker Repair and Services

Through our local power technology service partners, we offer **breaker repair, maintenance and services**.

- Service Contracts

ABB recognizes that many customers are highly self-reliant for their service and support needs, only requiring occasional training and support. Other customers want to outsource their service requirements completely. Whether the requirement is for training, on-line troubleshooting, preventative maintenance or



an emergency site visit, an ABB Service Contract is a **flexible and cost effective way** for customers to realize the benefits of ABB's product, system, application, and process expertise. Each agreement is tailored to the **customer's specific needs** from elements such as:

- **365 days 24 hour priority Hot Line service**
- **ABB University Training at select ABB facilities or on customer site**
- **Remote Diagnostics**
- **Preventive maintenance**

- Innovative Financial Arrangements



Via third party banks, ABB offers a range of **financial services** to help customers finance rectifier upgrades and improvements, including operating leases / off balance sheet financing and capital leases. These leasing arrangements are all subject to credit approvals by the third party lessor.

- Technical Support / Remote Diagnostics



In today's complex technology environment, it is impossible for anyone to be an expert on all products and processes. **On-line expertise** is the answer. With the control upgrades further discussed herein, customers can benefit from significantly enhanced diagnostics,

24 x 365 on line support and remote diagnostic capability.

- Recommended Spares for Long Term Operation

ABB provides a detail list of recommended spares. Availability of critical spares is a key element to **reduce MTTR** (Mean Time To Repair). ABB will assist in review of your system spare parts inventory recommending...

- Hotline



ABB's Service Hot Lines provide fast, easy and reliable access to our rectifier support engineers. Services are available **24 hours per day, 365 days per year.**



Example of a turnkey upgrade installation upgrading DC power level and retrofit of power and control equipment.



ABB Switzerland Ltd
Shripad Tambe
Head of Sales and Projects
Power Electronics Service – ATPS
5300 Baden / Turgi, Switzerland
Tel: +41 58 589 37 95
Fax: +41 58 589 30 00
E-Mail: shripad.tambe@ch.abb.com
Internet: www.abb.com/powerelectronics

**Contact us for One Stop
Rectifier Support.**

We care for you.